

# The biomechanics of interference screw fixation of patellar tendon anterior cruciate ligament grafts

CHARLES H. BROWN, JR.,\* MD, AARON T. HECKER,† MS, JOHN A. HIPPEL,† PhD,  
ELIZABETH R. MYERS,† PhD, AND WILSON C. HAYES,†† PhD

*From the †Orthopaedic Biomechanics Laboratory, Department of Orthopaedic Surgery, Charles A. Dana Research Institute, Beth Israel Hospital and Harvard Medical School, and \*Harvard Community Health Plan, Boston, Massachusetts*

## ABSTRACT

Twenty-seven paired human cadaveric knee specimens were used to determine the effect of surgical technique and various interference screw parameters on the pullout strength of patellar tendon femoral bone blocks. The study compared the fixation strength of endoscopically inserted and conventional "rear-entry" screws of different diameters and lengths. In all tests the most frequent mode of failure was bone block pullout from the interference screw. There was no significant difference in fixation strength between 9-mm diameter screws inserted through a conventional rear-entry technique and 7-mm diameter screws inserted through an endoscopic technique. There was no significant effect of screw length on fixation strength. The pullout force for 20-mm long screws increased on average 120% when 7-mm diameter screws were compared with 5.5-mm diameter screws. There was no significant effect of increased screw core diameter on fixation strength. There was a weak positive correlation ( $r^2 = 0.45$ ) between screw insertion torque and pullout force. Our measured mean pullout force for the 7-mm endoscopically inserted screws of  $362 \pm 198$  N represents 20.1% of the failure load of the normal young adult anterior cruciate ligament. Our data indicate that properly inserted 7-mm diameter endoscopic interference screws can provide fixation strengths of patellar tendon anterior cruciate ligament grafts equivalent to those of conventional 9-mm diameter rear-entry, outside-in screws.

The ACL is one of the most frequently injured ligaments in the knee. Miyasaka et al.<sup>18</sup> reported an annual incidence of 60 acute knee ligament injuries resulting in pathologic tibiofemoral joint motion per 100,000 patients in a southern California health maintenance organization. The ACL injuries accounted for approximately 50% of these injuries, making it the most frequently injured ligament. Based on these data, there are an estimated 75,000 acute ACL tears in the United States each year.<sup>18</sup>

The biomechanical importance of the ACL is now well established.<sup>5,10,18</sup> As a result, intraarticular replacement of the ACL has become the operative procedure of choice for the treatment of a torn ACL.<sup>8</sup> The success of intraarticular ACL reconstruction is influenced by many factors. These include graft selection,<sup>20</sup> graft placement,<sup>1,12,13,17,19,22,26-28,33</sup> graft tension,<sup>3,6,26,28</sup> graft fixation,<sup>4,14,15</sup> and the postoperative rehabilitation program.<sup>21,25,31,32</sup> Studies by Noyes et al.,<sup>21</sup> Shelbourne and Nitz,<sup>31</sup> and Shelbourne and Wilckens<sup>32</sup> have shown the advantages of early motion and aggressive postoperative rehabilitation in reducing the morbidity and improving the results of ACL surgery. A major limiting factor in the early postoperative rehabilitation of patients after ACL reconstruction is the initial fixation strength of the ACL graft. Holden et al.<sup>14</sup> used a goat model to demonstrate that ACL graft fixation failure was the major cause of failure in the immediate postoperative period before biological incorporation of the graft fixation site.

Because of their favorable biomechanical properties, patellar tendon autografts are most widely used for autogenous ACL reconstructions.<sup>2,20</sup> In addition to their excellent initial mechanical properties, bone-to-bone fixation of patellar tendon grafts can be achieved through a variety of methods. Lambert<sup>16</sup> first described interference screw fixation of patellar tendon grafts with a 6.5-mm AO cancellous screw.

† Address correspondence and reprint requests to: Wilson C. Hayes, PhD, Orthopaedic Biomechanics Laboratory, Beth Israel Hospital, 330 Brookline Avenue, Boston, MA 02215.

Kurosaka et al.,<sup>15</sup> in an in vitro study using human cadaveric specimens, demonstrated the superior initial fixation strength of a custom-designed, fully threaded 9-mm interference screw compared with a 6.5-mm AO cancellous screw. As a consequence, fully threaded interference screws have become the standard implant for fixation of ACL bone-tendon-bone grafts.

Rosenberg,<sup>30</sup> Olson et al.,<sup>23</sup> and Paulos et al.<sup>24</sup> have described endoscopic surgical techniques for reconstruction of the ACL. These endoscopic techniques are an attempt to reduce the morbidity of ACL reconstruction further by avoiding a lateral femoral incision and its associated dissection. The femoral bone tunnel is drilled in-line through the tibial tunnel. The patellar tendon ACL graft is fixed by inserting an interference screw from inside the joint.

Our objectives with this study were first to use an in vitro cadaveric model to compare the fixation strength of interference screws inserted so as to simulate endoscopic placement to that of interference screws inserted through a conventional rear-entry, outside-in approach. Our second objective was to study, using the same model, the effects of screw thread length, screw diameter, and screw core size on the fixation strength of patellar tendon ACL grafts. Finally, we wished to correlate interference screw insertion torque with fixation strength.

## MATERIALS AND METHODS

Paired human cadaveric knee specimens were used to minimize the effects of specimen-to-specimen bone density variations and to increase statistical power through the use of paired comparisons. The study was performed in three parts (Table 1). Part I compared the fixation strengths of 25-mm long, 7-mm diameter screws inserted so as to simulate endoscopic insertion to 9-mm diameter screws inserted through a conventional rear-entry, outside-in approach. Part II compared the fixation strengths of 5.5- and 7-mm diameter screws inserted in an endoscopic fashion. This was done for both 20 and 25 mm length screws. Part III compared the fixation strengths of 25-mm long, 5.5- and 7-mm diameter interference screws of both standard core and an experimental large-core design. The core dimensions of the 5.5-mm diameter screws were 3 mm for the standard core and 3.5 mm for the experimental large-core design. The core dimensions of the 7-mm diameter screws were 3.5 mm for the standard core size, and 4.42 mm for the experimental large-core design.

## Surgical technique

Paired, fresh-frozen, cadaveric knees were obtained through the Anatomical Gifts Program of Harvard Medical School. The mean age of the specimens was  $79 \pm 9$  SD years, with a range of 61 to 96 years. A total of 27 pairs were tested. All specimens were thawed to room temperature for 24 hours before the simulated ACL reconstructions were done.

Simulated ACL reconstructions were done with the knee specimen mounted in a vise and the tibia hanging free. A midline skin incision was made to expose the extensor mechanism. A 10-mm wide section from the middle third of the patellar tendon was cut using a metal template (Acufex Microsurgical Inc., Mansfield, MA) to ensure uniform specimen width. Bone blocks were also marked using the metal template. Tibial and patellar bone blocks measuring 10 mm in width, 25 mm in length, and 8 mm in depth were harvested using an oscillating saw (Ergo-Acufex 750, Storz/Ergo Instruments, Inc., Coranger, IN). The bone blocks were trimmed into a cylindrical shape to fit snugly through a 10-mm cylindrical metal sizing tube (Acufex Microsurgical Inc.), thus minimizing the gap between the bone tunnel and bone block.

To disarticulate the knee, we cut the capsule and collateral and cruciate ligaments. The ACL was cut in midsubstance, leaving the femoral attachment site of the ligament intact. Using endoscopic or rear-entry guides (Acufex Microsurgical Inc.), depending of the type of fixation, a 2.4-mm K-wire was drilled through the center of the femoral attachment site of the ACL. For simulated endoscopic reconstructions, a 10-mm endoscopic reamer (Acufex Microsurgical Inc.) was used to drill a 30-mm length tunnel into the lateral femoral condyle. For rear-entry, outside-in reconstructions, a 10-mm cannulated drill was used to drill a tunnel from the lateral femoral cortex through the femoral attachment site of the ACL into the intercondylar notch. The ACL soft tissue remnant was excised to facilitate graft passage.

The trimmed patellar bone block was inserted into the femoral bone tunnel in each specimen. The bone block was inserted into the femoral tunnel with the cancellous surface oriented anteriorly in all specimens. For simulated endoscopic reconstructions, the bone plug was inserted until flush with the intraarticular edge of the femoral bone tunnel. For rear-entry, outside-in reconstructions, the bone plug was placed flush with the lateral femoral cortex. To facilitate parallel screw-bone block placement in both procedures, a 1-mm K-wire was inserted along the bone block parallel to the long axis of the femoral bone tunnel, thus marking the

TABLE 1  
Experimental design

Part	Factors compared within specimens	Variables	Factors compared between specimens	Variables	Factors held constant
I	Surgical technique	Rear-entry Endoscopic			Screw length (25 mm) Screw core size (standard)
II	Screw diameter	5.5 mm 7.0 mm	Screw length	20 mm 25 mm	Surgical technique (endoscopic) Screw core size (standard)
III	Screw core size	Standard Large	Screw diameter	5.5 mm 7.0 mm	Surgical technique (endoscopic) Screw length (25 mm)

angle for screw insertion. The K-wire was removed, and an interference screw (Acufex Microsurgical Inc.) was inserted anterior to the bone block along its cancellous surface. The screw was advanced until flush with the edge of the bone block. A digital torque screw driver (Model TQJE-1000, Snap-on Tools Corp., Kenosha, WI) was used to measure the peak insertion torque for Parts I and III. The screw-bone block divergence angle, defined as the angle between the axis of the drilled bone tunnel and the interference screw, was directly measured in each specimen using a goniometer. The axis of the drilled bone tunnel was marked by inserting a K-wire between the bone tunnel and the bone block. The interference screw axis was then marked by inserting a removable screw driver blade into the hex head of the screw. A goniometer was then used to measure the angle between the two markers.

### Mechanical testing

In preparation for mechanical testing, the femur was stripped of all soft tissues. Mechanical tests were conducted on an Instron servohydraulic materials testing machine (Model 1331, Instron Corp., Canton, MA). The femoral shaft of each specimen was mounted in a custom clamping device attached to the actuator of the materials testing machine (Fig. 1). The patellar ligament was secured to the load cell using serrated clamps applied to the tibial bone block. The specimens were kept moist with sprayed saline during all mechanical testing. The orientation of the applied load was parallel to the long axis of the femoral bone tunnel. A preload of 10 N was applied to the specimen, and the construct was then loaded to failure in tension at a displacement rate of 1 mm/sec. The load-displacement curve was recorded using an automated data acquisition system (Lab Tech Notebook, Laboratory Technologies, Wilmington, MA). Pullout force at failure was defined as the point where the load-deflection curve deviated substantially from linear. The failure mode was also recorded for each specimen.

On completion of the pullout tests, an 8-mm diameter cylindrical core of trabecular bone 10 mm in height was removed from the lateral femoral condyle adjacent to the ACL bone tunnel using a diamond-tipped coring tool (Starlite Corp., Rosemont, PA). Marrow and soft tissues were removed with a water jet, supplemented by periodic agitation in an ultrasonic cleaner. The apparent density of the trabecular core was determined using standard protocols.<sup>7</sup> To provide estimates of the pullout forces that might be expected in young femora, a linear correction factor based on apparent density was applied to the measured pullout data.<sup>7</sup> This linear estimate was given by  $F_c = F_a(0.8/p_a)$ , where  $F_c$  is the estimated pullout force in Newtons,  $F_a$  is the measured pullout force, and  $p_a$  is the measured apparent bone density in grams per cubic centimeter. The value 0.8 g/cm<sup>3</sup> is the average femoral trabecular apparent density in young adult bone.<sup>11</sup>

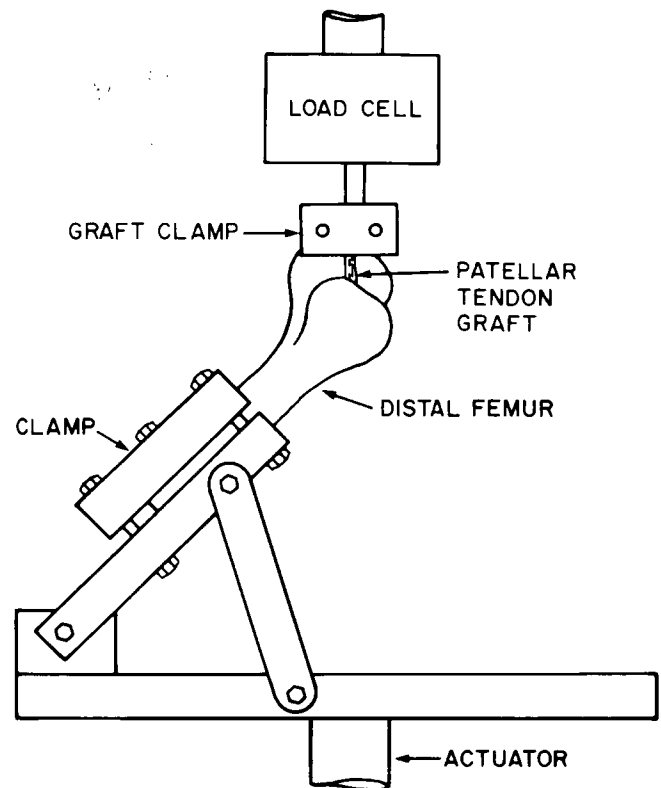

**Figure 1.** The femoral shaft of each specimen was attached to the actuator of an electrohydraulic materials test system. The patellar ligament was secured to the load cell using serrated clamps applied to the tibial bone block.

### Data analysis

The data from Part I comparing the simulated endoscopic insertion technique to the conventional rear-entry, outside-in technique were analyzed by a paired *t*-test. The data from Parts II and III were analyzed by a two-factor analysis of variance with one within-subjects factor and one between-subjects factor (Table 1). The null hypothesis of equal failure loads was rejected if the significance level was less than 0.05.

## RESULTS

Average measured insertion torques, ultimate pullout force, and linear stiffness are recorded in Table 2. The mean screw-bone block divergence angle for screws inserted so as to simulate endoscopic placement was  $5.8^\circ \pm 5.7^\circ$ . The failure mode of simulated endoscopic reconstructions of Part I was bone block pullout in four specimens and both screw and bone block pullout in one specimen. For the rear-entry reconstructions of Part I, the failure mode was bone block pullout in four of the five specimens and bone block fracture in one. Based on a paired *t*-test, there was no statistically significant difference in pullout force ( $P = 0.76$ ) or insertion torque ( $P = 0.07$ ) between the simulated endoscopic screws and the conventionally inserted, rear-entry, outside-in screws.

TABLE 2  
Insertion torque, pullout force, linear stiffness

Part	Experiment	Screw length (mm)	Screw diameter (mm)	Core size	No.	Insertion torque (N-m)	Pullout force (N)	Linear stiffness (N/mm)
I	Endoscopic versus rear-entry	25	7.0	Standard	5	0.56 ± 0.25	256 ± 130	70.2 ± 28.9
		25	9.0	Standard	5	1.20 ± 0.73	235 ± 124	82.8 ± 30.1
II	Screw diameter	20	5.5	Standard	5		123 ± 77	32.7 ± 11.0
		20	7.0	Standard	5		270 ± 109	50.8 ± 17.3
		25	5.5	Standard	7		267 ± 165	61.6 ± 31.1
		25	7.0	Standard	7		322 ± 178	81.1 ± 61.9
III	Core size	25	5.5	Standard	5	0.79 ± 0.72	358 ± 231	93.8 ± 48.7
		25	5.5	Large	5	0.88 ± 0.42	315 ± 226	80.6 ± 53.3
		25	7.0	Standard	5	0.99 ± 0.60	466 ± 283	82.5 ± 54.1
		25	7.0	Large	5	1.16 ± 0.72	409 ± 192	105.9 ± 67.0

For the comparison of 5.5- and 7-mm diameter screws of two given lengths (Part II), the failure mode in four of the five 5.5-mm diameter, 20-mm long screws was bone block pullout and in one specimen both bone block and screw pullout. For the 7-mm diameter screws, three specimens failed by bone block pullout and two by bone block and screw pullout. For the 25-mm long screws, the failure mode in five of the seven 5.5-mm diameter screws was bone block pullout and in two specimens, bone block and screw pullout. For the 7-mm diameter screws, three specimens failed by bone block pullout and four by bone block and screw pullout.

By analysis of variance (ANOVA), there was no significant effect of screw length on pullout force ( $P = 0.27$ ), but there was a highly significant increase in pullout force for the 7-mm diameter screws when compared with the 5.5-mm diameter screws ( $P = 0.002$ ). The ANOVA interaction term between length and diameter was also significant ( $P = 0.024$ ), indicating that the effect of screw diameter was not the same for each screw length. For the 20-mm long screws, the pullout force on average increased 120% when 7-mm diameter screws were inserted rather than 5.5-mm diameter screws. For the longer screws (25 mm), the pullout force increased only 21% on average when the diameter of the screw was increased from 5.5 to 7 mm.

For the comparison of standard versus increased core diameter 5.5- and 7-mm diameter screws (Part III), the failure mode for the 5.5-mm standard core screws was tendon failure in one specimen, bone block and screw pullout in one specimen, and bone block pullout in the remaining three specimens. For the 5.5-mm large core screws, all five specimens failed by bone block pullout. The failure mode for the 7-mm standard core screws was bone plug fracture at the top of the screw in one specimen, bone plug and screw pullout in two specimens, and bone plug pullout in two specimens. For the 7-mm large core screws, the failure mode was tendon failure in one specimen, bone plug and screw pullout in one specimen, and bone pullout in three specimens.

By ANOVA, there was no significant difference in pullout force ( $P = 0.17$  for 5.5-mm screws and  $P = 0.29$  for 7-mm screws) or insertion torque ( $P = 0.59$  for 5.5-mm screws and

$P = 0.21$  for 7-mm screws) between the standard and large core screws.

Using the combined data from Parts I and III for 5.5- and 7-mm diameter endoscopically inserted screws and 9-mm outside-in inserted screws, there was a weak positive linear correlation ( $r^2 = 0.45$ ,  $P < 0.05$ ) between screw insertion torque and measured pullout force (Fig. 2). The standard error of the estimate in pullout force from Figure 2 was 155 N.

Table 3 list the average apparent densities, the estimated pullout forces using the linear correction factor, and the percentage increases from the measured pullout force. The increase in the measured pullout forces ranged from 134% for 25-mm long, 7-mm large core diameter screws, to 298% for 9-mm outside-in inserted screws.

## DISCUSSION

In this cadaveric model system there was no significant difference in fixation strengths for interference screws in-

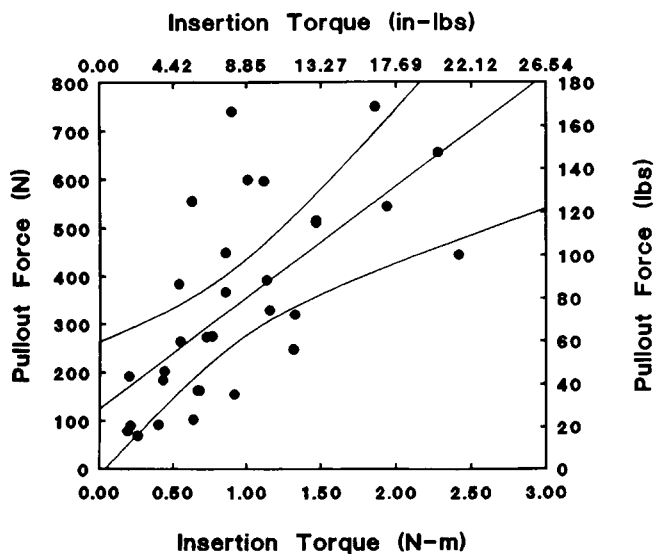

Figure 2. For endoscopically inserted screws of 5.5 and 7 mm diameter and 9 mm inserted outside-in, there is a weak but significant ( $r^2 = 0.45$ ,  $P < 0.05$ ) positive linear correlation between screw insertion torque and measured pullout force.

TABLE 3  
Bone densities, corrected pullout forces

Part	Experiment	Screw length (mm)	Screw diameter (mm)	Bone density (g/cm <sup>3</sup> )	Corrected pullout force (N)	Percent increase
I	Endoscopic versus rear-entry	25	7.0	0.25 ± 0.08	814 ± 456	219
		25	9.0	0.23 ± 0.09	933 ± 591	298
II	Screw diameter	20	5.5	0.30 ± 0.22	435 ± 453	253
		20	7.0	0.26 ± 0.10	825 ± 240	206
		25	5.5	0.29 ± 0.08	708 ± 367	165
		25	7.0	0.30 ± 0.08	872 ± 456	171
III	Core size	25	5.5 standard	0.27 ± 0.13	987 ± 477	176
		25	5.5 large	0.23 ± 0.09	1044 ± 458	231
		25	7.0 standard	0.28 ± 0.10	1238 ± 562	166
		25	7.0 large	0.34 ± 0.14	956 ± 119	134

serted as to simulate endoscopic placement and screws inserted through a conventional rear-entry, outside-in approach. With the endoscopic model, interference screw length (20 mm versus 25 mm) and screw core diameter (for 5.5-mm diameter screws, 3-mm standard core versus 3.5-mm large core; for 7-mm screws, 3.5-mm standard core versus 4.42-mm large core) did not influence fixation strength. However, for 20-mm long interference screws of standard core diameter, an increase in screw diameter from 5.5 to 7 mm resulted in a 120% increase in pullout force. For 5.5- and 7-mm endoscopically inserted screws and 9-mm outside-in interference screws, there was also a moderate ( $r^2 = 0.45$ ) positive linear correlation between insertion torque and pullout force.

Kurosaka et al.,<sup>15</sup> in a previous report on ACL fixation, compared the fixation strength of a 6.5-mm diameter AO cancellous screw with that of a custom-designed, 9-mm diameter, fully threaded cancellous interference screw. Their study did not examine the effect of screw length or screw core size on the fixation strength of ACL patellar tendon grafts. There have also been no previous studies comparing the fixation strength of endoscopically inserted interference screws with that of the conventional rear-entry, outside-in interference screws.

To address these open questions, we chose an experimental design so that bone density could be controlled for a pair of knees, thus minimizing the effects of this variable for a given experimental condition. In our model we found no significant difference in pullout force between the endoscopically inserted 7-mm diameter screws, and the rear-entry, outside-in inserted 9-mm diameter screws ( $P = 0.76$ ). Our data thus suggest that properly inserted 7-mm diameter endoscopic interference screws can provide fixation strengths of patellar tendon ACL grafts equivalent to those of conventional 9-mm diameter rear-entry, outside-in screws.

One important limitation of our study is that in our endoscopic model the interference screws were inserted in an open fashion. This open insertion method is likely to have allowed a more parallel screw placement (mean screw-bone block divergence angle of  $5.8^\circ \pm 5.7^\circ$ ) than is possible

using an arthroscopic approach. Because the endoscopic screw is commonly inserted through an anteromedial portal with the arthroscopic technique, parallel screw-bone block placement is more difficult to obtain. Thus, arthroscopic screw placement might be expected to result in larger screw-bone block divergence angles and a reduction in screw thread-bone block contact (and possibly fixation strength) compared with our open insertion technique. We are currently exploring this issue in a further series of experiments designed to determine the effects of controlled variations in divergence angle on graft fixation strength.

When the effect of screw length and diameter on pullout force was analyzed, we found a significant difference between the 20- and 25-mm long screws. Our results indicate that for 20-mm long endoscopically inserted screws, stronger fixation is obtained with 7-mm diameter screws than with 5.5-mm diameter screws. For 25-mm long screws our data suggest that there is no significant difference in pullout strength between the 5.5- and 7-mm diameter screws, although there is a trend toward higher failure loads for the 7-mm diameter screws. Based on our data, endoscopic fixation with a 7-mm diameter and 20- or 25-mm length screw can provide fixation strengths equivalent to conventional rear-entry, outside-in fixation with 9-mm diameter screws. Our data thus provide some clinical guidelines for endoscopic screw selection.

The use of the large-core screw design did not provide increased fixation strength in our model. Instead the mean fixation strengths of both the 5.5- and 7-mm large-core designs were lower than the corresponding standard-core screws, but these differences were not significant. The failure of the large-core design to improve ACL graft fixation performance is probably the consequence of a reduction in the amount of cancellous bone within the threads of the large-core diameter screw. Our findings agree with those of DeCoster et al.,<sup>9</sup> who showed that increases in screw pullout force in a synthetic bone material were most sensitive to the screw outer diameter and least sensitive to increases in the core size of the screw.

Our measured mean pullout force of  $362 \pm 198$  N for the 7-mm diameter, standard-core, endoscopically inserted

screws compares favorably with mean values of  $208 \pm 27.5$  N for a 6.5-mm AO cancellous screw and  $476 \pm 111$  N for a custom-designed, 9-mm diameter screw previously reported by Kurosaka et al.<sup>15</sup> Expressed as a percentage of the failure load for the normal young adult ACL of 1725 N,<sup>20</sup> our measured pullout strength in elderly cadavers ranged from 13.6% to 26.8% of the normal ACL failure load. This compares favorably with values of 12% to 27.5% of the normal ACL previously reported by Kurosaka et al.

Another limitation of our study, and of other similar ACL fixation studies, is the use of elderly cadaveric specimens. Other authors have noted that cadaver age—and by inference, bone density—has an effect on the fixation strength of ACL grafts.<sup>8</sup> Because of the difficulty of obtaining young knee specimens, we measured the apparent density of trabecular bone next to the femoral tunnel. We attempted to estimate what the fixation strength might be in young femora by using a linear correction factor based on the measured apparent density of the specimen (Table 3). Estimated fixation strengths ranged from  $814 \pm 456$  N to  $1238 \pm 562$  N for 7-mm diameter, 25-mm long endoscopic screws. These values represent 47.2% to 71.8% of the normal young adult ACL failure load derived from the experiments by Noyes et al.<sup>20</sup> The estimated fixation strength of the 9-mm diameter, 25-mm long rear-entry screws was  $933 \pm 591$  N. This represents 53.9% of the failure load of the normal young adult ACL. Our data suggest a 134% to 298% greater pullout force might be expected for young femora compared with the measured pullout forces obtained in these elderly specimens.

The actual force on the ACL during activities has not been directly measured, but Noyes et al.<sup>20</sup> estimated that the ACL is loaded to approximately 450 N for most normal activities. Based on our measured data, the mean failure load for the 5.5-mm diameter, standard-core, 25-mm long screws was  $358 \pm 226$  N, with a range of 69 to 599 N, representing 79.6% of the average estimated load associated with activities of daily living. The mean failure load for the 7-mm diameter, standard-core, 25-mm long screws was  $466 \pm 283$  N, with a range of 79 to 750 N. This represents on average 104% of the estimated ACL force during activities of daily living. Using a linear correction factor based on apparent density, we estimated a value of  $1238 \pm 562$  N for the 7-mm diameter, standard-core, 25-mm long screws, or 275% of the estimated ACL force with activities of daily living. Based on these data, it appears that 7-mm diameter, standard-core, 25-mm long endoscopic screws could provide adequate ACL graft fixation strength during the early postoperative period.

Reznik et al.,<sup>29</sup> in an adult minipig model, reported that when screw insertion torques were 1 foot-pound (1.36 N-m) or greater, the patellar tendon pullout strength was above 150 pounds (667 N). Based on our insertion torque data, an insertion torque of 1 foot-pound correlated with a pullout force of 438 N. With additional data, a positive correlation of this kind could provide the surgeon with an intraoperative estimate of the immediate fixation strength. These data

could then be used to help guide the early postoperative rehabilitation program.

## CONCLUSIONS

1. Pullout strength of patellar tendon ACL grafts secured using conventional rear-entry, outside-in, 9-mm diameter screws did not differ significantly from 7-mm diameter screws inserted so as to simulate endoscopic placement ( $P = 0.76$ ). Insertion torques were not significantly higher for the 9-mm diameter, rear-entry screws compared with the 7-mm diameter screws ( $P = 0.07$ ). We can conclude, therefore, that both fixation techniques provide similar fixation strengths, even though screw diameter was larger for the rear-entry technique.

2. From the repeat measure ANOVA, there was no significant effect of screw length on pullout force ( $P = 0.27$ ), but there was a highly significant increase in pullout force for the 7-mm diameter screw compared with the 5.5-mm diameter screw ( $P = 0.002$ ). The significant ( $P = 0.024$ ) ANOVA interaction term (length\*diameter) indicates that the influence of screw diameter differed for the two screw lengths.

3. The repeat measure ANOVA revealed no significant effect of core diameter on pullout force ( $P = 0.17$  for 5.5-mm diameter screws and  $P = 0.25$  for 7-mm diameter screws). There was also no significant effect of core diameter on insertion torque. These two results suggest that increased screw core diameter does not improve interference screw fixation strength over conventional interference screws.

4. There was a weak but positive linear correlation ( $r^2 = 0.45$ ,  $P < 0.05$ ) between screw insertion torque and measured pullout force.

## ACKNOWLEDGMENTS

We acknowledge the assistance of Joseph A. Sklar, MD, Mr. Jeff Wyman, and James Karlson, MD, for their help in performing the surgical dissections. This study was supported by Acufex Microsurgical, Inc., the Harvard Community Health Plan Foundation (CHB), and the Maurice Edmond Müller Professorship in Biomechanics (WCH) at Harvard Medical School.

## REFERENCES

1. Acker JH, Drez D: Analysis of isometric placement of grafts in ACL reconstruction procedures. *Am J Knee Surg* 2: 65-70, 1989
2. Andrews JR, Indelicato PA, Noyes FR, et al: Surgical controversies: Autografts or allografts for ACL reconstruction. *Strategies for Rehabilitative Orthopaedics Biodex Professional Services* 1: 2-5, 1989
3. Burks RT, Leland R: Determination of graft tension before fixation in anterior cruciate ligament reconstruction. *Arthroscopy* 4: 260-266, 1988
4. Butler DL: Evaluation of fixation methods in cruciate ligament replacement. *Instr Course Lect* 36: 173-178, 1987
5. Butler DL, Noyes FR, Grood ES: Ligamentous restraints to anterior-posterior drawer in the human knee: A biomechanical study. *J Bone Joint Surg* 62A: 259-270, 1980
6. Bylski-Austrow DI, Grood ES, Hefzy MS, et al: Anterior cruciate ligament replacements: A mechanical study of femoral attachment location, flexion angle at tensioning, and initial tension. *J Orthop Res* 8: 522-531, 1990
7. Carter DR, Hayes WC: The compressive behavior of bone as a two-phase porous structure. *J Bone Joint Surg* 59A: 954-962, 1977

8. Clancy WG: Arthroscopic anterior cruciate ligament reconstruction with patellar tendon. *Techniques Orthop* 2: 13-22, 1988
9. DeCoster TA, Heetderks DB, Downey DJ, et al: Optimizing bone screw pullout force. *J Orthop Trauma* 4: 169-174, 1990
10. Dye SF, Cannon WD: Anatomy and biomechanics of the anterior cruciate ligament. *Clin Sports Med* 7: 715-725, 1988
11. Gibson LJ, Ashby MF: Cancellous bone, in Gibson LJ (ed): *Cellular Solids*. New York, Pergamon Press, 1988, pp 316-331
12. Graf B: Isometric placement of substitutes for the anterior cruciate ligament, in Jackson DW, Drez D (eds): *The Anterior Cruciate Deficient Knee*. St. Louis, CV Mosby, 1987, pp 102-113
13. Hefzy MS, Grood ES, Noyes FR: Factors affecting the region of most isometric femoral attachments. Part II. The anterior cruciate ligament. *Am J Sports Med* 17: 208-216, 1989
14. Holden JP, Grood ES, Butler DL, et al: Biomechanics of fascia lata ligament replacements: Early postoperative changes in the goat. *J Orthop Res* 6: 639-647, 1988
15. Kurosaka M, Yoshiya S, Andrish JT: A biomechanical comparison of different surgical techniques of graft fixation in anterior cruciate ligament reconstruction. *Am J Sports Med* 15: 225-229, 1987
16. Lambert KL: Vascularized patellar tendon graft with rigid internal fixation for anterior cruciate ligament insufficiency. *Clin Orthop* 172: 85-89, 1983
17. Melhorn JM, Henning CE: The relationship of the femoral attachment site to the isometric tracking of the anterior cruciate ligament graft. *Am J Sports Med* 15: 539-542, 1987
18. Miyasaka KC, Daniel DM, Stone ML, et al: The incidence of knee ligament injuries in the general population. *Am J Knee Surg* 4: 3-8, 1991
19. Muller W: *The Knee: Form, Function, and Ligament Reconstruction*. New York, Springer-Verlag, 1983
20. Noyes FR, Butler DL, Grood ES, et al: Biomechanical analysis of human ligament grafts used in knee-ligament repairs and reconstructions. *J Bone Joint Surg* 66A: 344-352, 1984
21. Noyes FR, Mangine RE, Barber S: Early knee motion after open and arthroscopic anterior cruciate ligament reconstruction. *Am J Sports Med* 15: 149-160, 1987
22. Odensten M, Gillquist J: Functional anatomy of the anterior cruciate ligament and a rationale for reconstruction. *J Bone Joint Surg* 67A: 257-262, 1985
23. Olson EJ, DiGioia AM, Harner CD, et al: Total quadriceps sparing, arthroscopic anterior cruciate ligament reconstruction. *Pitts Orthop J* 1: 16-19, 1990
24. Paulos LE, Cherf J, Rosenberg TD, et al: Anterior cruciate ligament reconstruction with autografts. *Clin Sports Med* 10: 469-485, 1991
25. Paulos LE, Payne FC, Rosenberg TD: *Rehabilitation After Anterior Cruciate Ligament Surgery*. St. Louis, CV Mosby, 1987, pp 291-314
26. Penner DA, Daniel DM, Wood P, et al: An in vitro study of anterior cruciate ligament graft placement and isometry. *Am J Sports Med* 16: 238-243, 1988
27. Reznik AM, Daniel DM: ACL graft placement, tensioning and fixation, Part II. *Surg Rounds Orthop* 4(9): 21-24, 1990
28. Reznik AM, Daniel DM: ACL graft placement, tensioning and fixation, Part I. *Surg Rounds Orthop* 4(8): 13-16, 1990
29. Reznik AM, Davis JL, Daniel DM: Optimizing interference fixation for cruciate ligament reconstruction. *Trans Orthop Res Soc* 15: 519, 1990
30. Rosenberg TD: Technique for endoscopic method of ACL reconstruction. Technical Bulletin, Acufex Microsurgical Inc, Mansfield, MA, 1989
31. Shelbourne KD, Nitz P: Accelerated rehabilitation after anterior cruciate ligament reconstruction. *Am J Sports Med* 18: 292-299, 1990
32. Shelbourne KD, Wilckens JH: Current concepts in anterior cruciate ligament rehabilitation. *Orthop Rev* 19: 957-964, 1990
33. Sidles JA, Larson RV, Garbini JL, et al: Ligament length relationships in the moving knee. *J Orthop Res* 6: 593-610, 1988